

LAUNDRY
pull-out hamper

18" 300.3148.xxx
24" 300.3140.xxx
30" 300.3143.xxx

FEATURES

Sort as you go with this set of individually removable soft laundry hamper bags

Comfortable hand grips for easy carrying

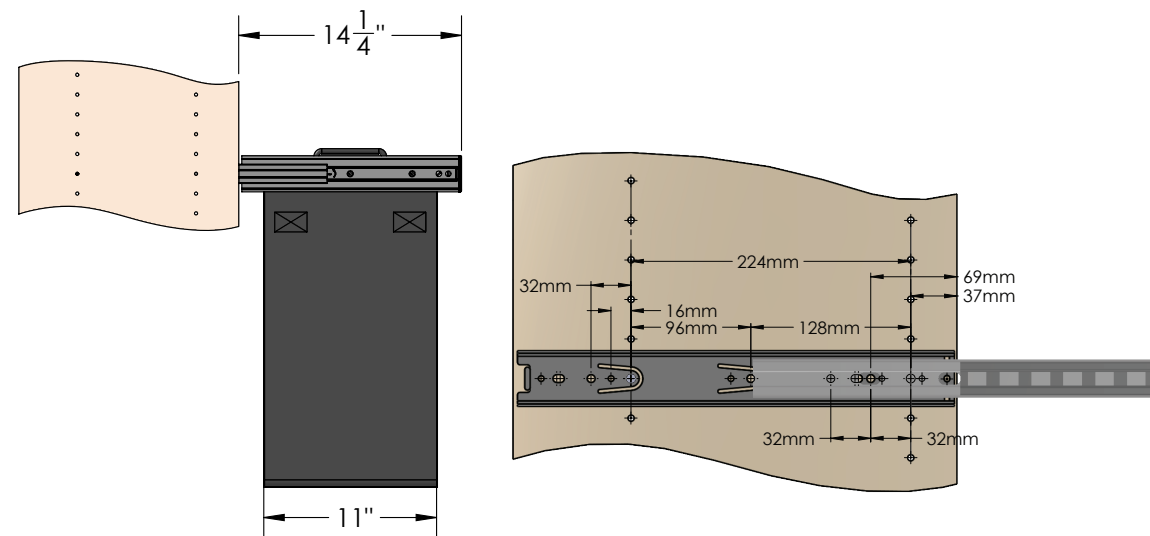
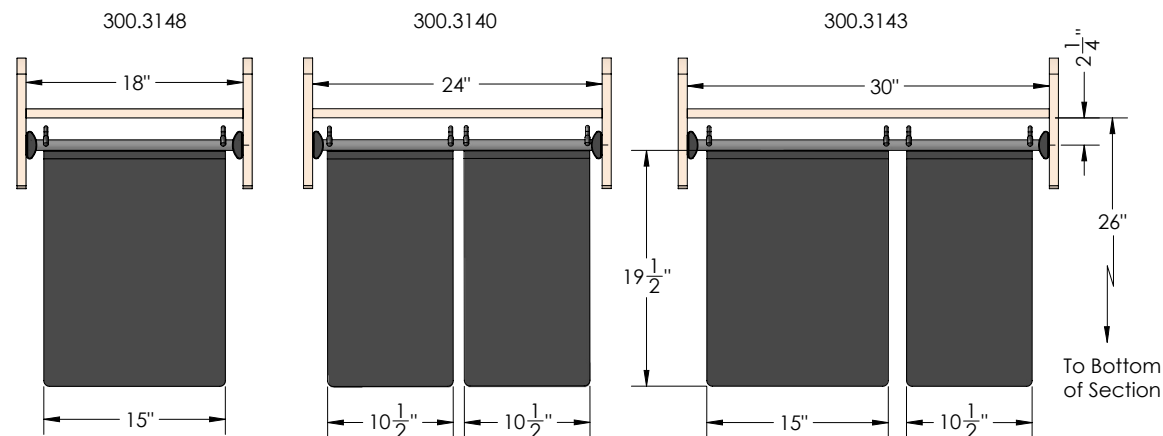

DIMENSIONS

SPECS

18"	24"	30"
300.3148.xxx (FINISH)	300.3140.xxx (FINISH)	300.3143.xxx (FINISH)

OPTIONS

FINISH:

- CR: POLISHED CHROME
- MAL: MATTE ALUMINUM
- MNL: MATTE NICKEL
- ORB: OIL RUBBED BRONZE



300.3143.MAL
PATENT #: 7210659

FINISHED PRODUCT