

ELITE
shoe fence corner posts

300.3175.xxx

FEATURES

Helps to create a unified corner on L-shaped shoe shelves

- Can also be used to frame pull out shelves and floating angled shoe shelves

- These Corner Posts provide greater versatility for your designs, allowing for new and unique applications of the ELITE Shoe Fence

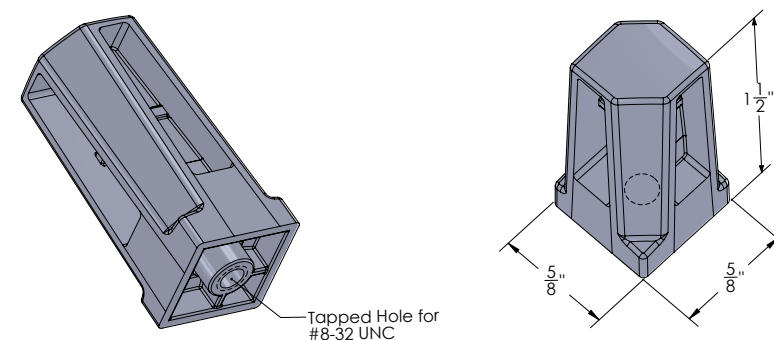
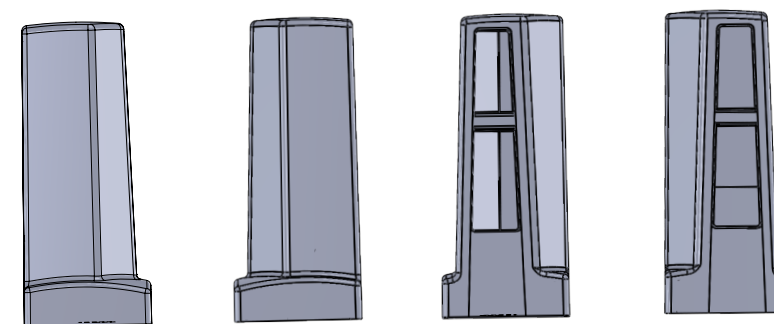

DIMENSIONS

SPECS

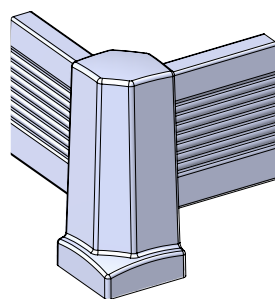

300.3175.^(FINISH)xxx

FINISH:

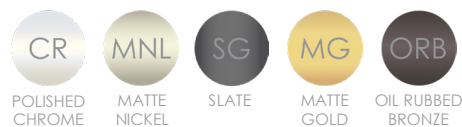

OPTIONS

APPLICATIONS

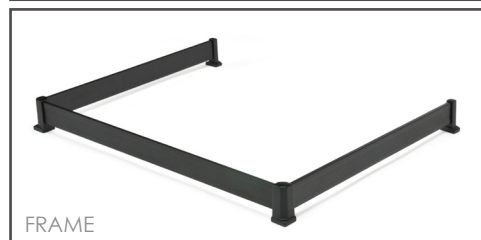
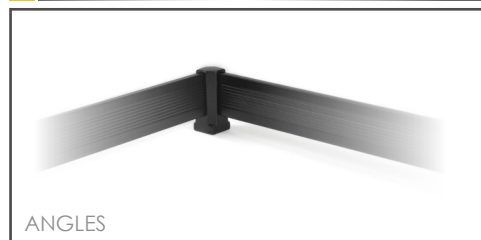

300.3175.CR

FINISHED PRODUCT