

ELITE

35" sliding full rotation mirror

300.3430.35.xxx

FEATURES

The compact 35" height of this mirror allows it to be installed in upper hanging sections

- Full extension ball bearing slides provide greater flexibility, extending the pivot point further out from the front edge of the closet – allowing for full rotation

- The full extension mirror is ideal when installation is required on the outside of a panel and rotated inwards

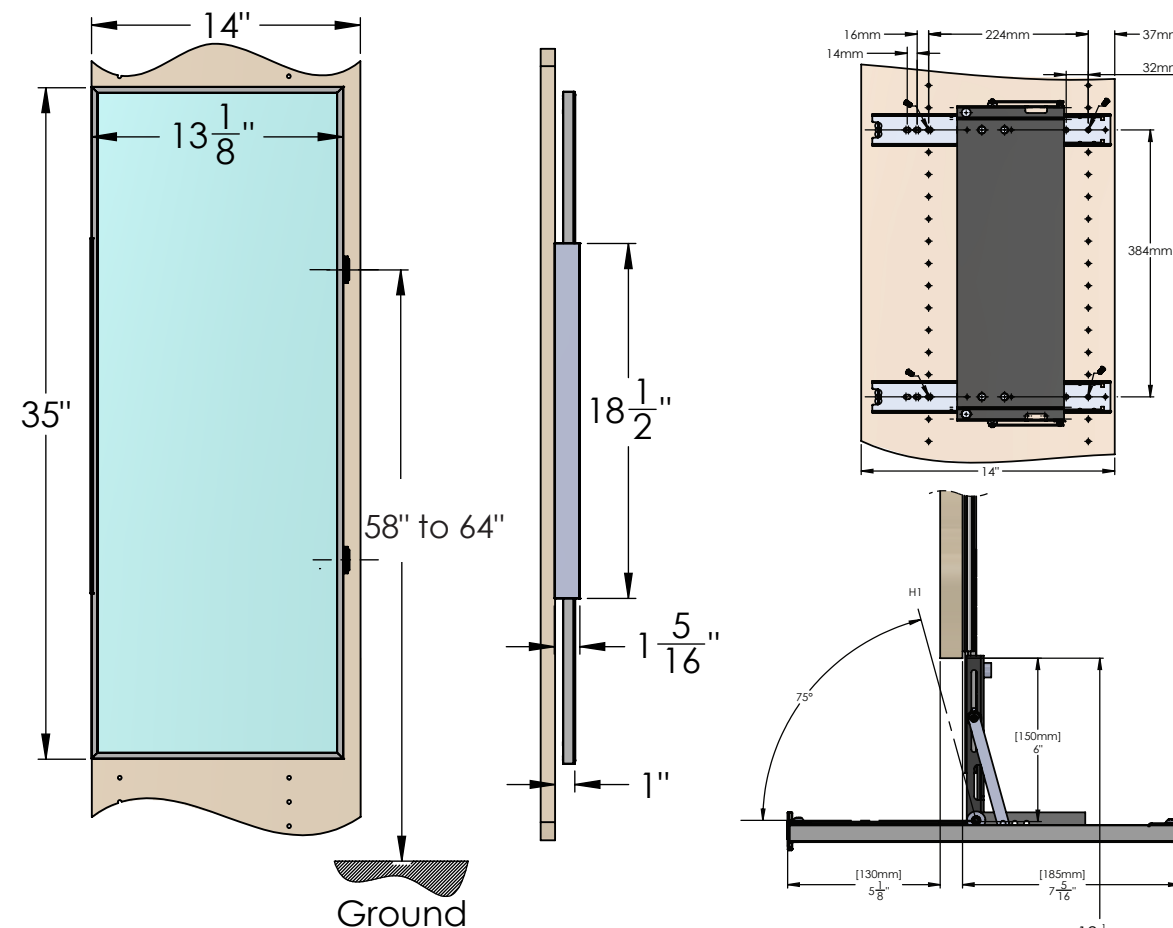

DIMENSIONS

SPECS

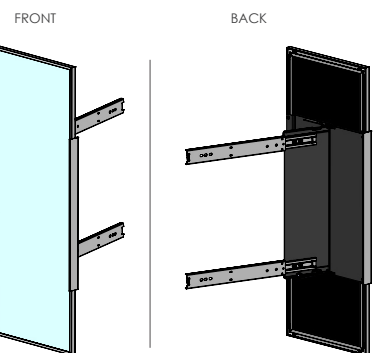

300.3430.35.xxx (FINISH)

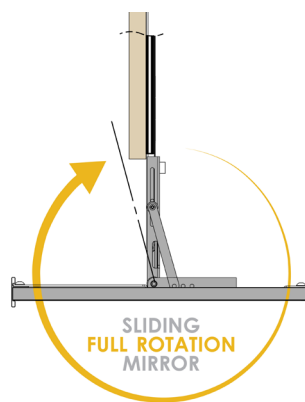

HEIGHT:
35"

WIDTH:
13 1/8"

- FINISH:**
- MAL MATTE ALUMINUM
 - MNL MATTE NICKEL
 - SG SLATE
 - MG MATTE GOLD
 - ORB OIL RUBBED BRONZE

FLEXIBLE INSTALLATION
Conveniently install on either the left or right side of a panel.

- For desired mirror position, place bracket in one of three holes:**
1. First hole next to bracket, full rotation
 2. Second (middle) hole, not functional
 3. Third (last) hole, not functional



300.3430.35.MAL

FINISHED PRODUCT

OPTIONS